



## INSTALLATION MANUAL

### THE LAB SPORT SHIFTER

<i>Paddle mounting:</i> .....	2
<i>Actuator assembly:</i> .....	3
<i>Mounting Battery:</i> .....	5
<i>Wiring assembly:</i> .....	6
<i>Practical notes and suggestions:</i> .....	8
<i>Neutral gear selection:</i> .....	8
<i>Battery:</i> .....	8
<i>Inefficient gear shifting:</i> .....	8
<i>Use in case of rain:</i> .....	8
<i>Setup values via APP:</i> .....	8
<i>Wiring diagram:</i> .....	9

The Lab Motorsport  
Via Donatello 12/A  
MONZA (MB)  
ITALY  
+39 3484682833  
info@thelab-europe.com

## *Paddle mounting:*

The paddles kit is supplied already assembled, it will be enough to install it between the steering wheel and the hub using the existing holes or, if necessary, drilling the carbon plate in an appropriate manner.

It is possible to distance the blades from the steering wheel by inserting between the paddle and the hinge of the thicknesses and using longer screws (standard TBEI M4x14).

It is extremely important to fix the wiring to the column or steering wheel hub with two plastic clamps or tape to allow the extension of the spiral part only.



*Actuator assembly:*

- 1) Fix the support plate included in the kit to the tube on the right side of the tank using the supplied brackets;

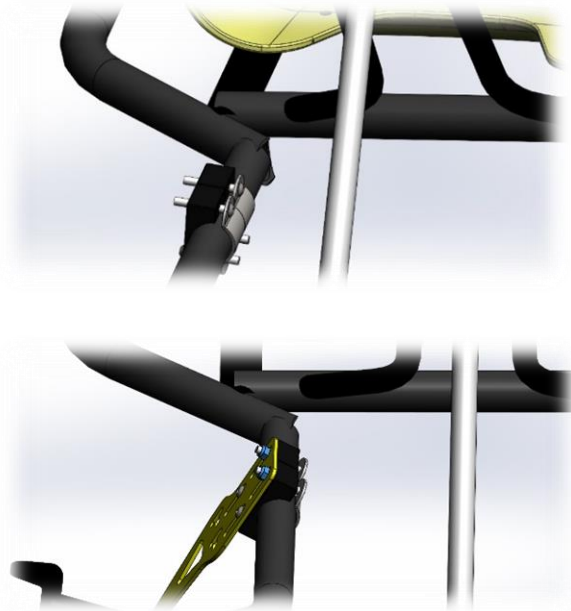

- 2) If necessary, the actuator can be rotated to keep it parallel to the rear axle using the holes on the plate;
- 3) It is extremely important to check actuator alignment in all directions:

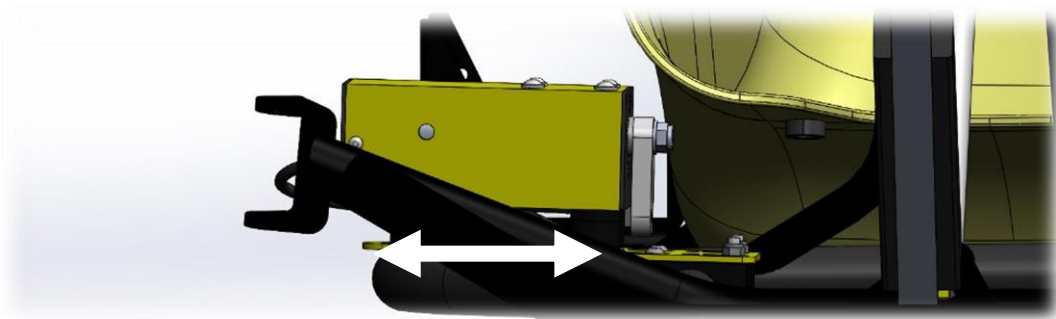
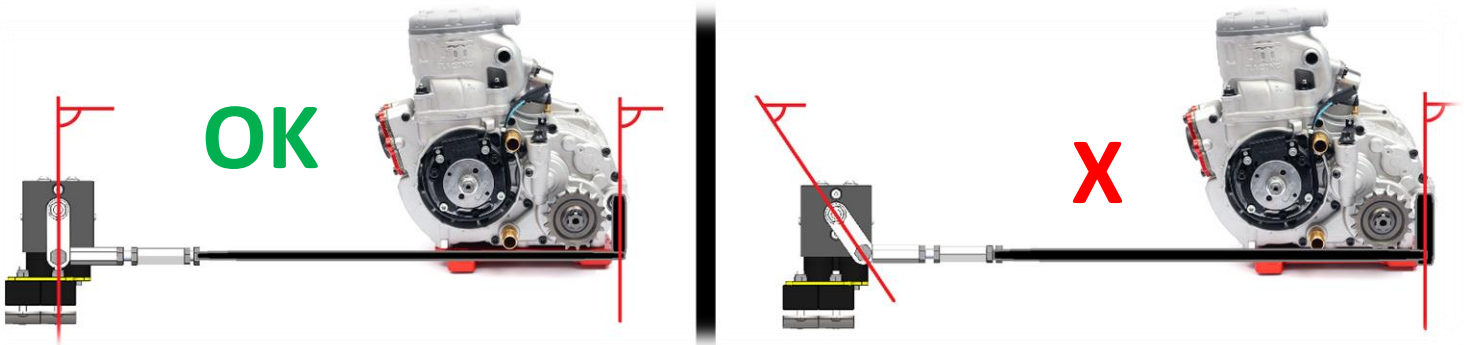

- 4) Lengthen the gear tie rod using the extension kit included in the kit;

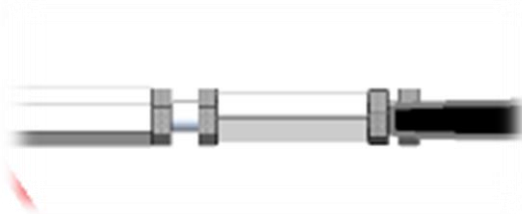

- 5) Fix the rod to the gear arm using the M8x20 hex head screw.

## *Mounting Battery:*

- 1) Attach the sponge adhesive strip to the front support and fix the battery holder with two plastic clamps;



- 2) Place the battery in the housing and lock it with the supplied red tape.



## Wiring assembly:

REFER TO ATTACHED ELECTRIC DIAGRAM. ALL CONNECTORS ARE PLU&PLAY, IT IS NOT POSSIBLE TO REVERSE THEM. **IT IS POSSIBLE TO CUT ALL CABLES THAT WERE NOT USED TO LIGHTEN THE WIRING AT THE END OF THE ASSEMBLY.**

- 1) Place the control unit on the high water pipe near the seat or on the seat using the integrated holder;



- 2) Arrange the wiring evenly by getting the connectors to the appropriate points of the frame;

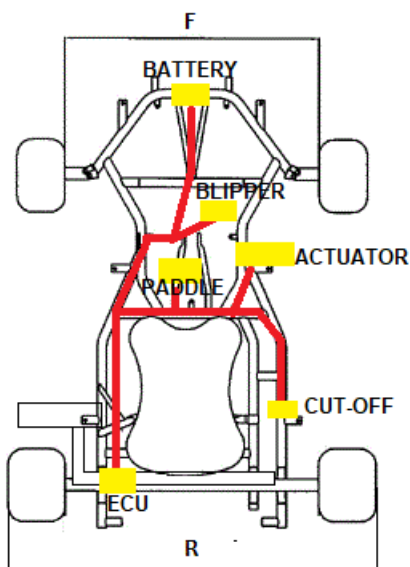

- 3) It is possible to cut and then insulate with electrical tape the cable parts not used for the go-kart by referring to the details in the electrical diagram attached (PERFORM THIS OPERATION WITHOUT POWER SUPPLY!);

- 4) Connect the cable "Cut-off C" (white color with male cylindrical connector) to the connector present on the coil, and the cable "cut-off NO" (green color with ring) to the mass of the engine.

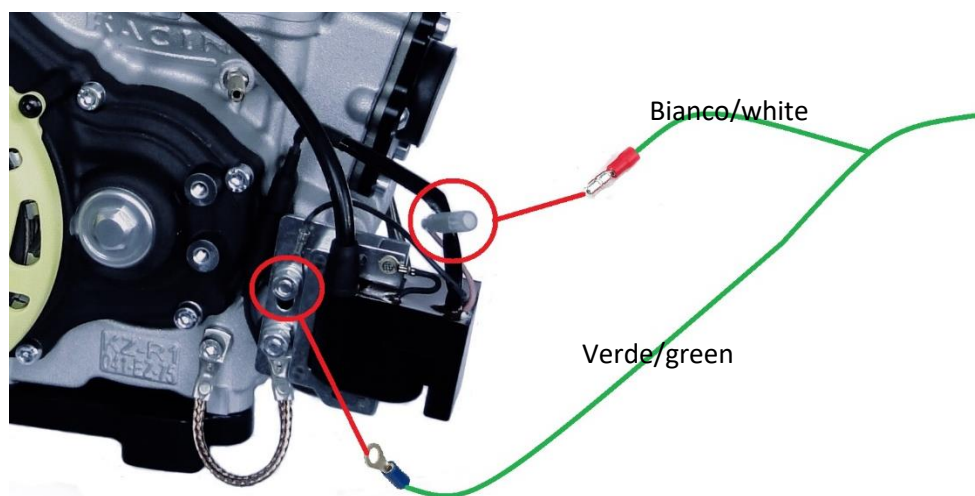

*Practical notes and suggestions:*

*Neutral gear selection:*

To enter the neutral gear you need to move into the first gear and then hold the left paddle for a second and release it. The actuator will give a weaker pulse of adjustable intensity (see manual APP for adjustment);

*Battery:*

The battery must always be charged before a track day and must be disconnected every end of the day. If the battery is left attached for several days it will suffer irreparable damage and must be replaced out of warranty (The check is carried out by checking the voltage of the cells).

*Inefficient gear shifting:*

If performance is lower than expected or changes are not accurate, or changes are missed, it is necessary to check the alignment of the actuator and arm, and make sure that during the movement the gear tie rod does not touch the water pipe or the seat. Referrals must be smooth and nothing must come into contact to ensure optimal performance.

*Use in case of rain:*

In case of use in the presence of rain, close the ventilation holes of the actuator with adhesive tape. The rain may short-circuit the internal engine. All remaining components enjoy IP67 protection and are not subject to risk.

*Setup values via APP:*

All indications and explanations regarding the setup of the gearbox parameters are described in the APP guide "the lab motorsport". The APP is now only available for Android devices.

---

---

---

---

---

---



## Wiring diagram:

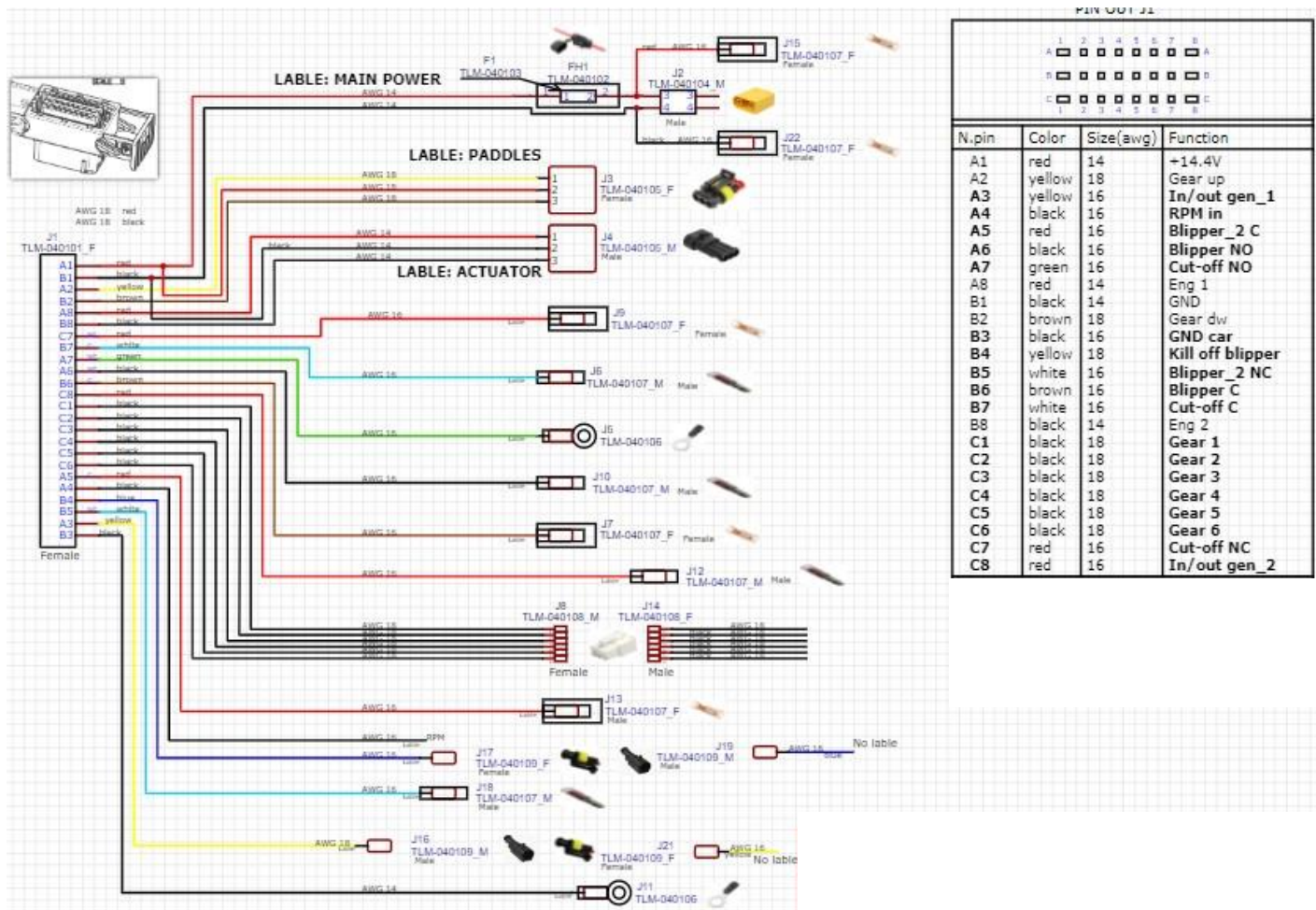

## WARNING:

The lab motorsport does not disclaim any liability arising from improper use or improper assembly of the product. Assembly is recommended only to specialized workshops.